



Power: 1.5 MW  
 Rotor: Ø 70/77 m  
 Tower heights:  
 65 / 100 m (mit 70 m Rotor)  
 61,5 / 100 m (mit 77 m Rotor)



# FL 1500

**F**  
**Fuhrländer**  
 AKTIENGESELLSCHAFT

**1** High security due to individual blade adjustment

**2** Combined planet spur wheel gear for high effectiveness

**3** Disk brake as 2<sup>nd</sup> safety system

**4** Variable speed, double-fed asynchronous generator for high profitability

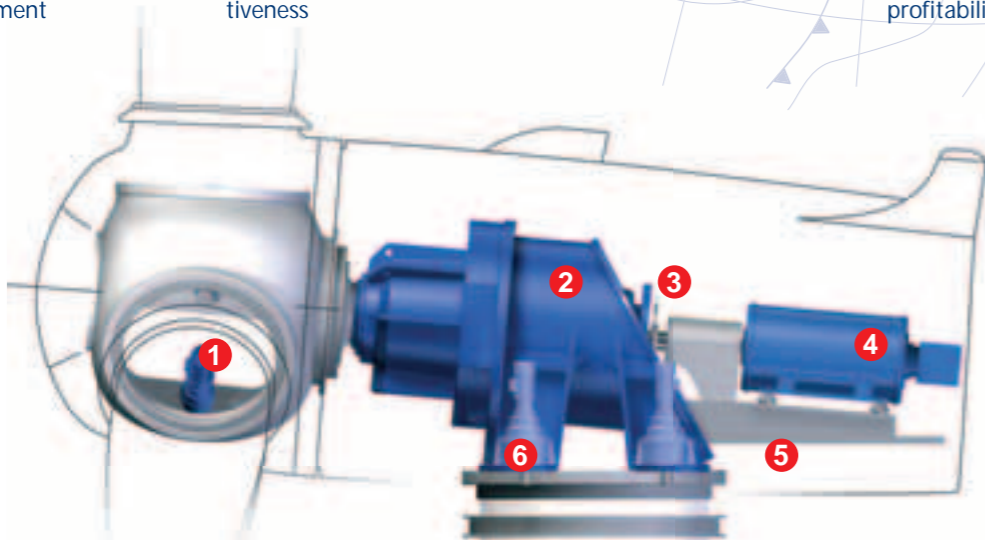

**6** Four azimuth driving motors for safe and stable wind direction tracking

**5** Robust and compact machine support with sound decoupling for the main components

## FL 1500: The compact turbine for all situations

Fuhrländer expanded its megawatt class by a compact, pitch controlled turbine, the FL 1500. The turbine adapts to coastal and interior locations due to its different hub heights and two different rotor sizes. Its individual blade adjustment via maintenance-free AC-motors and the integrated free running provide high operational safety. The intelligent torque control ensures a constantly high release of power to the long live, double-fed three phase generator.

### Rotor

Diameter	70 m / 77 m
Surface area	3'848 m <sup>2</sup> / 4'657 m <sup>2</sup>
No. of blades	3
Speed	11-22 / 9.7-19 min <sup>-1</sup>
Power control	pitch

### Gear

Design	Combined spur wheel/planet
Stages	3
Multiplication	1:90.038 / 1:104.125

### Generator

Design	Double-fed three-phase asynchronous machine
Speed	1000...1800 min <sup>-1</sup>
Voltage (frequency) Converter system	690 V (50/60 Hz) Puls-width modulated IGBT

### Power

Rated output	1,500 kW
at	12 / 11 m/s
Start wind	3.0 m/s
Stop wind	25 / 20 m/s
Survival speed	59.5 / 52.5 m/s

### Tower

Hub height	61.5/65/100/114.5 m
Design	tubular tower

### Weights

Rotor	32'500 / 34'000 kg
Nacelle	51'000 kg
Tower	93'000...260'000 kg

### Control

Speed control	Microprocessors
Yawing control	4 gear motors
Main brake	Blade angle adjustment
2 <sup>nd</sup> brake system	Disk brake
Monitoring	Fixed network/radio/Vabera

### Sound

Sound output level	103.3 / 104 dB (A) Measurement of 02.07.03
--------------------	---

Medium wind speed at hub height [m/s]	70 m Rotor Annual yield [kWh]	77 m Rotor Annual yield [kWh]
8.5	6'195'000	
8.0	5'699'000	
7.5	5'122'500	5'296'000
7.0	4'546'000	4'735'000
6.5	3'919'500	4'131'000
6.0	3'293'000	3'502'000
5.5	2'675'500	2'867'000
5.0	2'058'000	2'251'000
4.5	1'542'500	1'683'000
4	1'027'000	1'188'000

Power curve FL 1500  
 (70 m measured / 77 m theoretical)

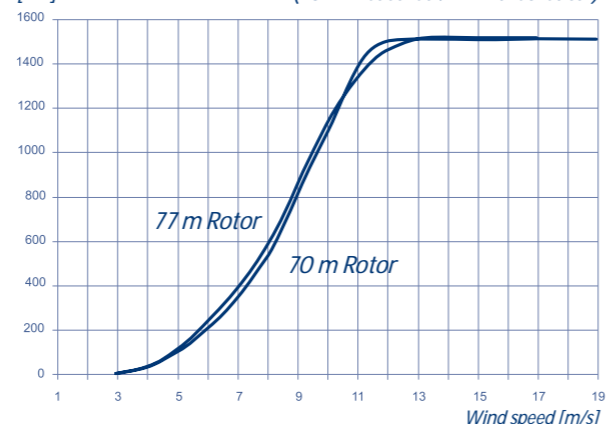

Subject to technical alterations. Data can vary depending on components.



Subject to technical alterations. Data can vary depending on components.